

CODE: **AWO200PU v.1.9/VII**
 NAME: **17/40/DSPR/L/PUSTA**

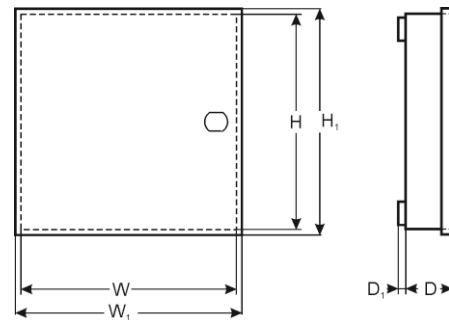

DESTINATION

DSC: (PC 1404, 1616, 1832, 1864, 4020, HS2016, HS2032, HS2064, HS2128) + 3x 5108 (4108, 5208, 5100,4116, HSM2108, HSM2208)

MODULES: (4204, 4216, 4580, 5400, 5204, 5580, 5200, GSM/GPRS 3G2060, GSM/GPRS TL260GS, GSM/HSPA 3G2080E, GSM/HSPATL2803GE) + 5x (4108, 5108, 5208, 5100, 4116, HSM2108, HSM2208)

PARADOX: (E55, E65, 728ULT,EVO48, EVO192, SP4000, SP5500, SP6000, SP7000) + 2 x Z X 8 (Z X 4, APR3- ADM2, APR3-HUB2, PGM4)

RISCO: PRO24, 116, 128, 140+ RP296EPS+ EZ16 (E04, EZ8)

SATEL: CA4V1, CA5, CA6

(VERSA5, 10, 15, CA10) + 2 x CA10E (CA64E, SM, MST1)

(INTEGRA24, 32) + 2 x CA64E (SM)

MODULES: CA64 (PP, EPS, ADR, O-R, O-ROC,O-OC, OPS- OC, OPS- R, OPS- ROC, VGM- 16, SR, PTSA) + 2 x CA64E (SM)

PYRONIX: MATRIX 424, 6, 816, 832, 832+

TEXECOM: PREMIER 412, 816, 832, 48, 88, 168, 640

TELMOR: TCA- 824 + TEX800+ TMT1

ROGER: PR402, CPR 32-SE

EBS: PX 202A

PULSAR: MS1012, MSR1012, MSRK1012

MS2012, MSR2012, MSRK2012

TECHNICAL DATA

External dimensions of the enclosure: W=320, H=400, D+D1=90+8 [+/-2 mm]

External dimensions of the front panel: W1=325, H1=405 [+/-2 mm]

Weight net/gross: 2,40kg / 2,60kg [+/-0,1kg]

Battery space: 17 Ah/12 V Sealed Lead Acid (SLA)

Transformer: without transformer- can be mounted in the casing: EI20, EI40, TRP20, TRP40, TRP50, TRP80, TRZ20, TRZ40, TRZ50, TRZ60, TRZ80, TOR50, TOR80, TOR100, TOR150.

Tamper protection: 1 x microswitch: opening, 0,5 A@50 V DC max. NC

Material description: sheet steel DC01, thickness: 0,7mm, protection anticorrosion, color: RAL 9003

Destination: indoor

Closing: screwed x 4

Notes: optional: lockable, distance from wall (mounting surface)- 8mm, easy door removal

Declaration, warranty: CE, 2 year from the production date